

electra form industries

ExStream Hot Runners for ISBM

EFI ExStream hot runner technology can be applied to all Injection Stretch Blow Molding PET machine applications including Aoki, Nissei, Uniloy and others.

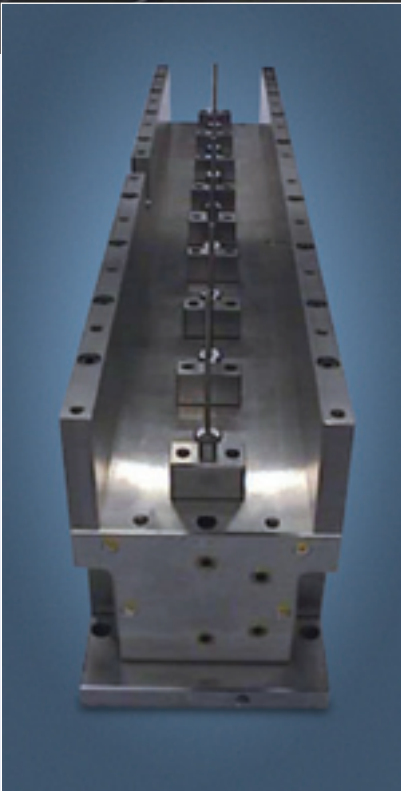

ExStream hot runner system for
Aoki 8 cavity mold

Typical features include:

- 2-step valve gated technology for ISB, (1 step) molds
- Valve stem removed from melt stream during injection results in:
 - Stream line melt flow
 - Eliminates material division — no knit lines
 - Reduces the effects of shear heat
- Effective inline melt delivery system through:
 - Revolutionary balanced design
 - Consistent weights across each shot
 - And allows for component interchangeability
- Pneumatic cylinders in water cooled plate
 - Piston seals last many years in production
 - Reduces preventative maintenance
- Short, even distribution nozzles provide:
 - Less residence time
 - Superior flow characteristics
- PET/Vespel/Titanium nozzle seals (unique for ISBM)
 - Superior heat isolation
 - Reduced gate crystallinity
 - Eliminates material stringing

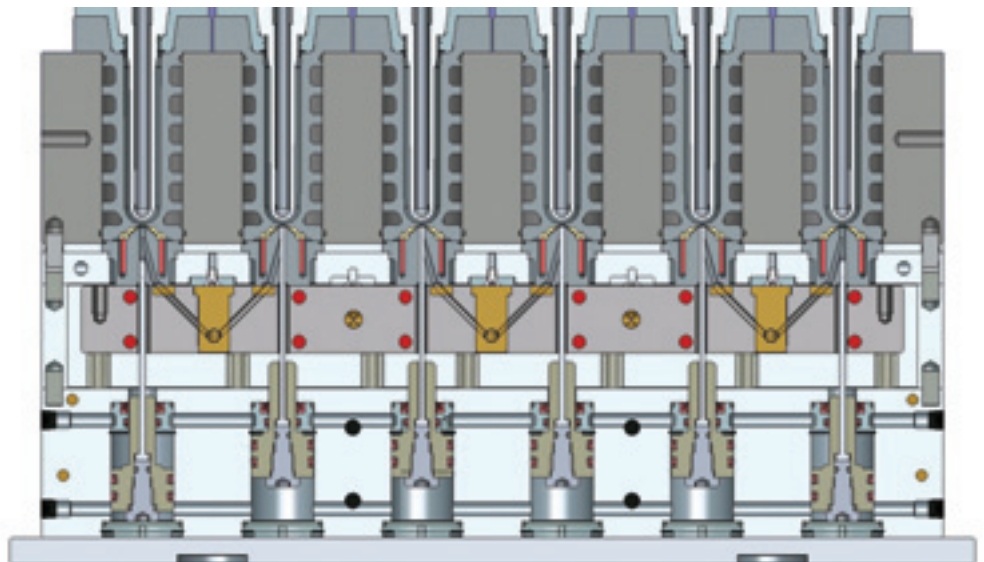

electra form industries

EMPACT Micropitch Technology for PET Molds

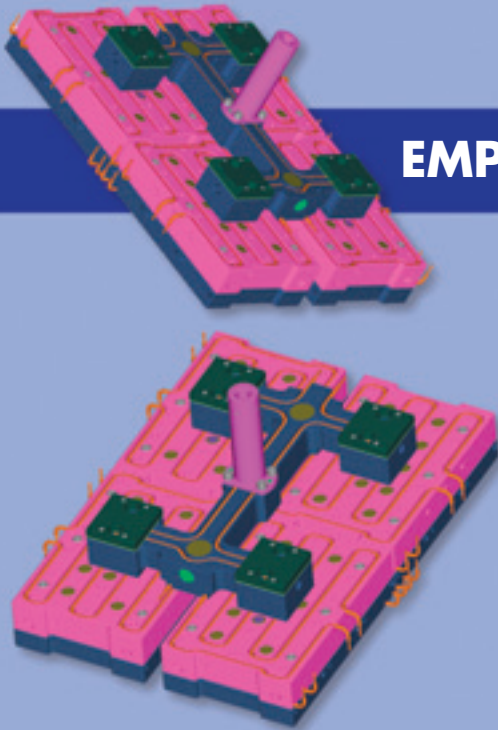

EFI's EMPACT 72 and 144 cavity PET molds are designed to fit all types of preform machines. "Plug and play" configuration allows water and pneumatic hook-ups to remain the same as with 48 and 96 cavity molds. This approach conserves plant space and significantly reduces capital investment as compared to similar platforms.

The pitch spacing between the units has been reduced, accommodating the additional cavitation. EMPACT molds have been designed to serve the 28mm beverage market and are targeted for preform weights of less than 60 grams. Productivity can increase by up to 1.5x with high output EMPACT molds.

EMPACT Micropitch technology includes:

- Independent, balanced hot runner design
- Based on ExStream manifold technology
- Pneumatic cylinders in water-cooled plate
 - Piston seals last a virtual lifetime
 - Reduces preventative maintenance
- PET/Vespel/Titanium nozzle seals
 - Superior heat isolation
 - Reduced gate crystallinity
 - Eliminates material stringing
- Easy piston assembly access

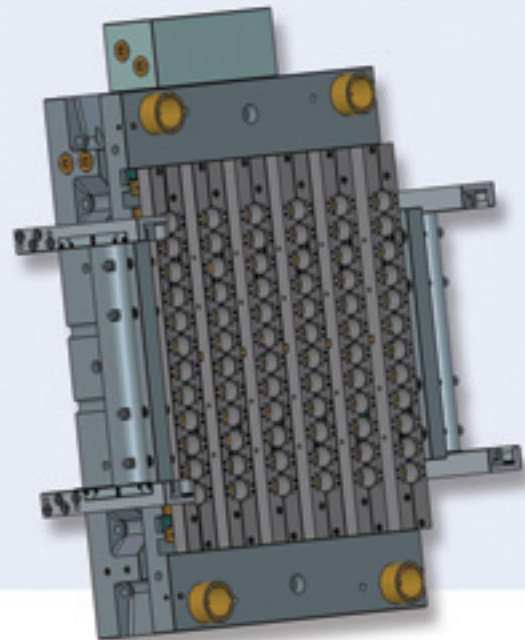

EMPACT molds offer best value, fast delivery and service response, and are supported by ISO 9001 quality standards unique in preform mold-making. Let EFI preform molds EMPACT your bottom line.

Electra Form Industries

852 Scholz Drive, Vandalia, Ohio 45377-3148, USA

Tel: 937-898-8460 Fax: 937-898-1750

E-mail: sales@electraform.com

website: www.electraform.com

